

BT – spiral bevel gear boxes

Solid and Hollow Shaft Design

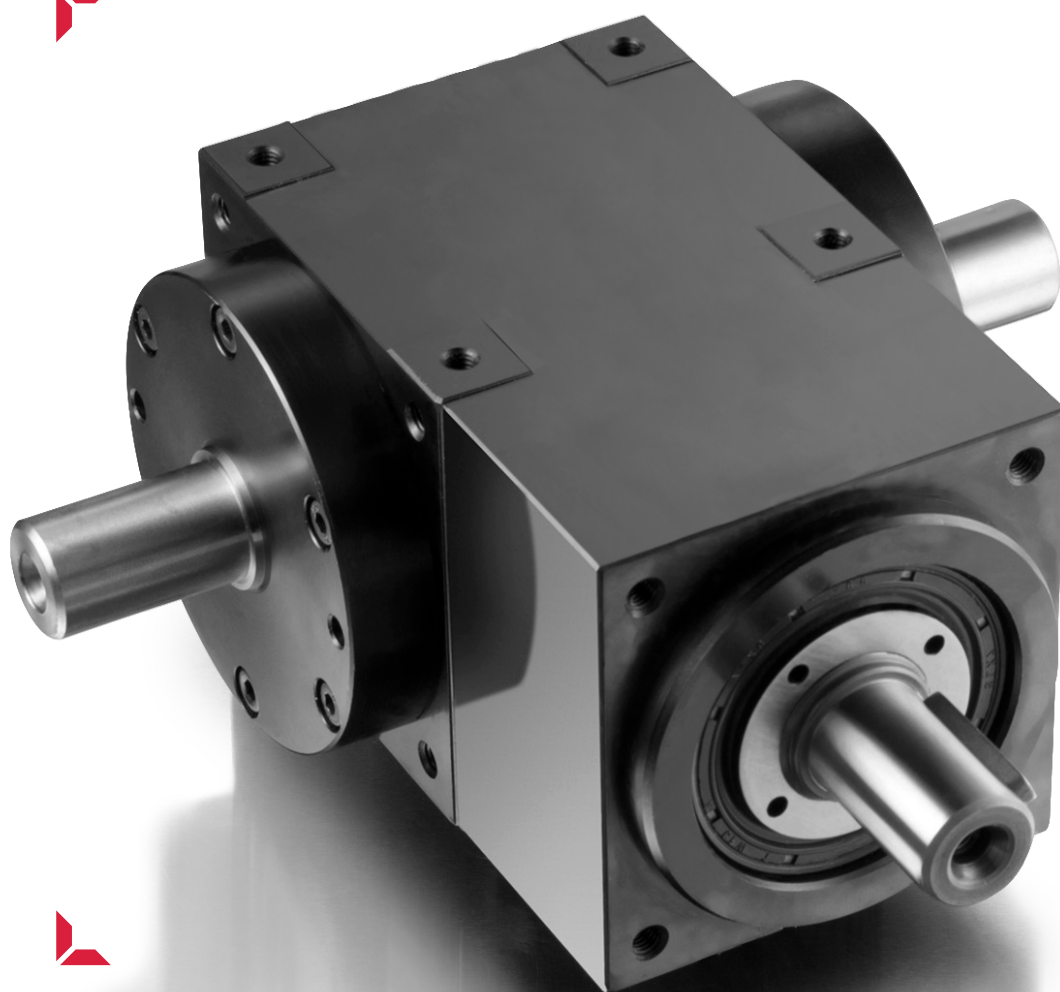

Zykloidgetriebe
Cycloid Gearboxes



Planetengetriebe
Planetary Gearboxes



Kegelrad-Planetengetriebe
Bevel Planetary Gearboxes



Kegelradgetriebe
Bevel Gearboxes

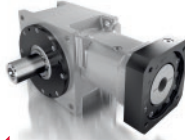

Hypoidgetriebe
Hypoid Gearboxes

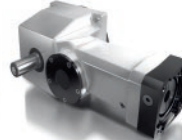

Hypoid-Stirnradgetriebe
Hypoid Helical Gearboxes



Getriebemotoren
Gear Motors



Verzahnungsentwicklung
Gear Development

EPPINGER BT bevel gear boxes

The BT range of bevel gear boxes is destined for all gear box applications which depend on reliability and variability. Compact dimensions and high transmission torque at optimal performance are of central importance here. Precision of the axes and bearing seats, combined with Gleason bevel gears to take high loads, are the basis for minimized tooth

clearance and optimal transmission properties. The gear boxes are presently available in 9 sizes, each with a ratio range of $i = 1 : 1$ to $5 : 1$. In addition, a further range of BM bevel gear boxes is available, which offers significantly greater torque at $i = 1 : 1$ at comparable sizes.

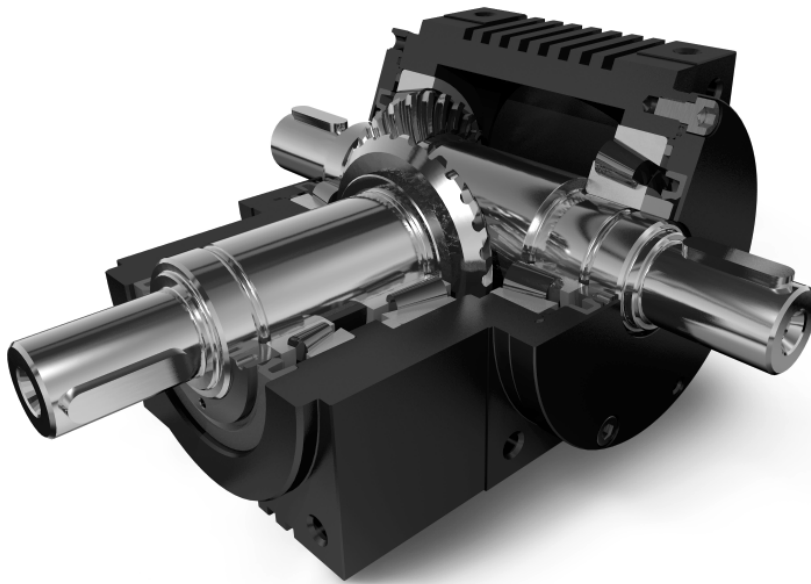

FEATURES AND BENEFITS OF THE NEW BT BEVEL GEAR BOX SERIES

THE HOUSING:

- single-component housing with maximum precision of axes and bearing seats, all integrated directly into the housing
- high power density of the gear boxes through compact housing dimensions
- drive-sided gear box interface offers the option of direct connection of planetary gear box pre-stages, as well as secure mounting of motor flanges
- mounting threads on all sides of the housing allow for stable attachment of the gear box in various installation positions

THE GEARS:

- heavy duty bevel gears, designed and manufactured according to the Gleason process, result in optimal gearing efficiency, high transmission precision and reduced stress on the bearings
- friction-locked, zero backlash connection of the crown gears on the drive shaft reduces the mass of the gearing component

- precise gear setting by measuring the gear box components and 100% running test of the gear boxes in assembly

SHAFTS AND BEARINGS:

- steel alloy shafts with precise bearing seats as basis for precise and heavy duty taper roller bearings
- extremely precise positioning and setting of bearings through the use of ground steel shims and splinting of the inner rings

THE RANGE OF GEAR BOXES:

- at present, 9 gear box sizes with a transmission ratio $i = 1 : 1$ to $5 : 1$
- gear box can be supplied with solid or hollow shafts in standard and customized designs
- best efficiency when high transmission performance is required. High efficiency levels of course result in a reduction of energy costs.

Performance data

	Abbreviation	Unit	Ratio	BT050	BT075	BT090	BT110	BT140	BT170	BT210	BT240	BT280
Rated output torque Emergency stop torque ¹	T _{2N}	Nm	i = 1 : 1	15	50	90	165	380	620	1250	2100	3100
	T _{2Not}	Nm		30	100	180	330	760	1240	2500	4200	6200
	T _{2N}	Nm	i = 1.5 : 1	15	50	90	165	380	620	1250	2100	3100
	T _{2Not}	Nm		30	100	180	330	760	1240	2500	4200	6200
	T _{2N}	Nm	i = 2 : 1	13	44	74	155	320	580	1180	2000	3000
	T _{2Not}	Nm		26	88	148	310	640	1160	2360	4000	6000
	T _{2N}	Nm	i = 3 : 1	-	35	55	125	245	470	980	1600	2700
	T _{2Not}	Nm		-	70	110	250	490	940	1960	3200	5400
	T _{2N}	Nm	i = 4 : 1	-	28	50	105	210	390	840	1400	2300
	T _{2Not}	Nm		-	56	100	210	420	780	1680	2800	4600
	T _{2N}	Nm	i = 5 : 1	-	25	40	90	175	340	720	1200	2000
	T _{2Not}	Nm		-	50	80	180	350	680	1440	2400	4000
Rated input speed	n _{1N}	rpm	i = 1 : 1	2500	2000	1700	1400	1100	1000	800	700	650
	n _{1N}	rpm	i = 1.5 : 1 / 2 : 1	3000	2500	2000	1600	1400	1300	1050	950	850
	n _{1N}	rpm	i = 3 : 1 - 5 : 1	-	3000	2500	2100	2000	1800	1600	1350	1200
Max. input speed ²	n _{1max}	rpm		7500	6500	5500	4500	3500	3000	2200	2000	1700
Max. permissible radial load ^{3,4}	F _{R1max}	N		300	950	1400	2100	3600	5000	8200	11000	15000
	F _{R2max}	N		400	1100	1600	2600	4600	6000	10000	15000	18000
Max. permissible axial load ⁴	F _{A1max}	N		150	500	700	1000	1800	2500	4000	5500	7500
	F _{A2max}	N		200	600	800	1300	2300	3000	5000	7500	9000
Torsional backlash output shaft		arcmin	standard	≤16	≤13	≤12	≤11	≤10	≤10	≤10	≤10	≤10
		arcmin	reduced	≤10	≤8	≤7	≤7	≤6	≤6	≤5	≤5	≤5
Efficiency at rated load	η	%		> 98								
Operating noise ⁵	L _{pa}	db(A)		70	70	73	75	76	77	80	81	82
Service life	L _h	h		> 15.000								
Lubrication	Synthetic oil, ISO VG 150 (up to size 140 incl.)											
Operating temperature	°C											
	-20 to 90											
Weight ⁶	kg			1.5	5.2	8.3	14.0	26.0	42.0	72.0	105	160
As-delivered condition	Housing and flanges burnished black											
Mass moment of inertia ⁷	I ₁	kgcm ²		Upon request								

¹ 1000x permissible short overload peaks during service life of gear boxes

² requires special measures

³ referred to center of shaft journal

⁴ reduced values for nominal torque/nominal speed

⁵ for nominal speed and partial load

⁶ with output shaft design S13

⁷ referred to the input shaft

Thermal limit rating

	Abbreviation	Unit	BT050	BT075	BT090	BT110	BT140	BT170	BT210	BT240	BT280	
Thermal limit rating ⁸	P _{therm}	kW	2.0	5.0	7.5	11.0	18.0	26.5	35.0	45.0	55.0	
Definition: the thermal limit rating P _{therm} is the transferable output during continuous operation at a max. permissible oil bath temperature of 90 °C. The permissible limit values for the thermal limit rating for intermittent operation can be determined as reference values as a function of rotational speed n1 and ambient temperature by applying the correction factors given below. In this context the effective output must not exceed the permissible limit values. P _{therm, effective} < P _{therm, permissible}			Drive speed [rpm] correction factor K1			0.4*n1N	0.7*n1N	n1N				
						1.0	0.8	0.5				
			Switch-on time ED [%] Correction factor K2			100	80	60	40	20		
Example:	Gear	Revolution speed	ED	Ambient				1.0	1.2	1.4	1.6	1.8
Permissible thermal limit rating at:	BT110 1 : 1	560 rpm	60%	40°C	Ambient temperature [°C] correction factor K3			10	20	30	40	50
P _{therm, permissible} = P _{therm} (BT110) x K1 x K2 x K3 = 11.0 kW x 1.0 x 1.4 x 0,7 = 10.8 kW						1.20	1.00	0.83	0.70	0.60		

⁸ at T2N, i = 1:1, RT=20°C and ED = 100%

Solid Shaft Design

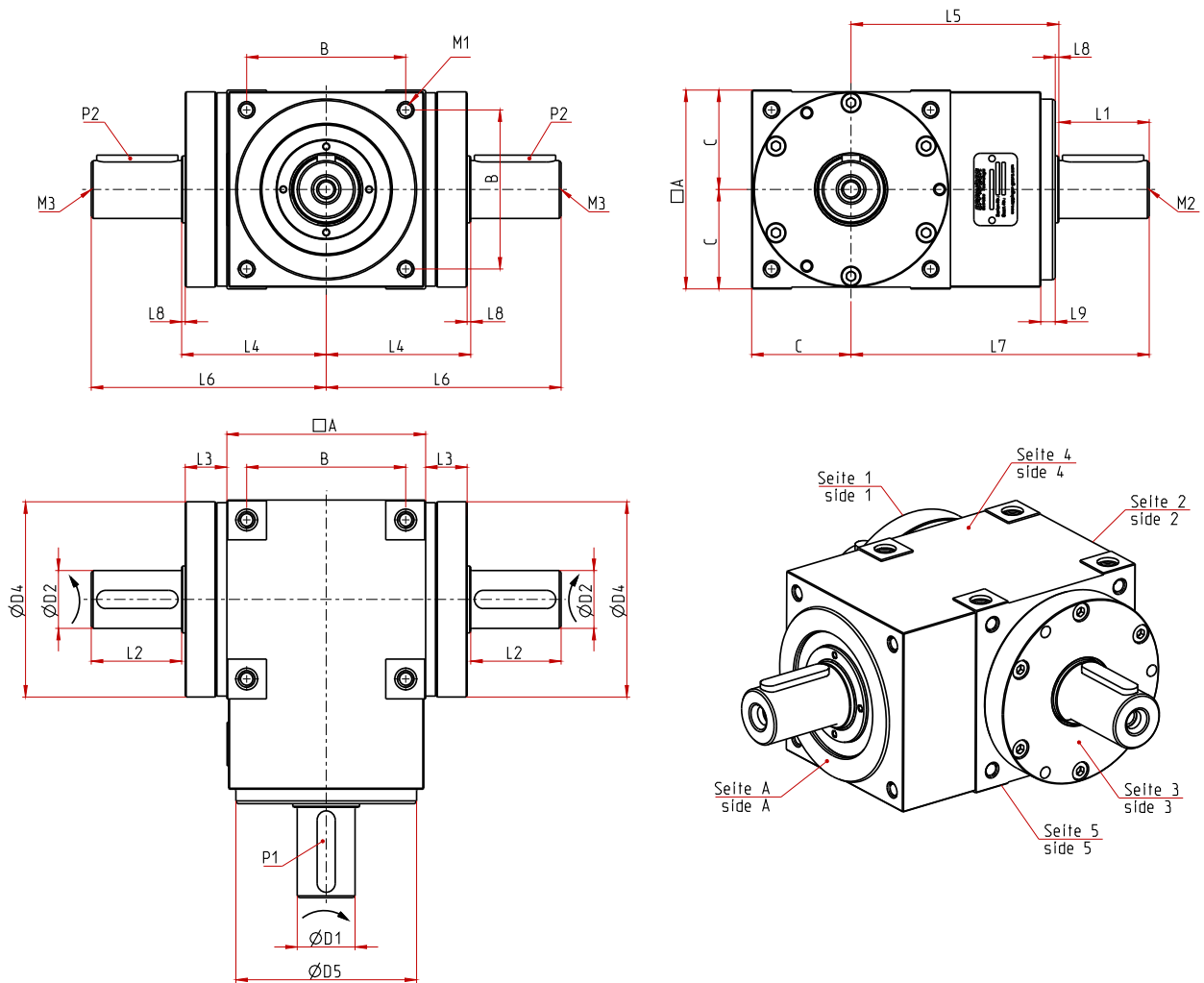

Solid Shaft Design (dimensions in mm)

	BT050	BT075	BT090	BT110	BT140	BT170	BT210	BT240	BT280
□ A	50	75	90	110	140	170	210	240	280
B	38	60	72	88	110	134	170	190	220
C	25	37.5	45	55	70	85	105	120	140
Ø D1	12 k6	18 k6	20 k6	25 k6	32 k6	40 k6	50 k6	60 k6	70 k6
Ø D2	12 k6	18 k6	20 k6	25 k6	32 k6	40 k6	50 k6	60 k6	70 k6
Ø D4	49 h7	73 h7	88 h7	108 h7	135 h7	165 h7	205 h7	235 h7	275 h7
Ø D5	45 g6	67 g6	80 g6	100 g6	120 g6	128 g6	158 g6	178 g6	208 g6
L1	23	30	35	40	50	60	80	100	120
L2	23	30	35	40	50	60	80	100	120
L3	8.5	14.5	15	15	18	15	20	25	25
L4	35.5	54	62	72	90	102	127	147	167
L5	60	90	100	115	130	155	190	215	250
L6	58.5	84	97	112	140	162	207	247	287
L7	83	120	135	155	180	215	270	315	370
L8	2	2	2	2	2	2	2	2	2
L9	5	6	8	8	8	10	14	68	83
P1	4x4x18	6x6x25	6x6x28	8x7x32	10x8x45	12x8x50	14x9x70	18x11x90	20x12x110
P2	4x4x18	6x6x25	6x6x28	8x7x32	10x8x45	12x8x50	14x9x70	18x11x90	20x12x110
M1	M5x9	M5x10	M6x12	M8x16	M10x20	M12x24	M16x32	M16x32	M16x32
M2/M3*	M4	M6	M6	M8	M10	M16	M16	M20	M20

* Thread in shaft end acc. to form DS, DIN 332

Hollow Shaft Design

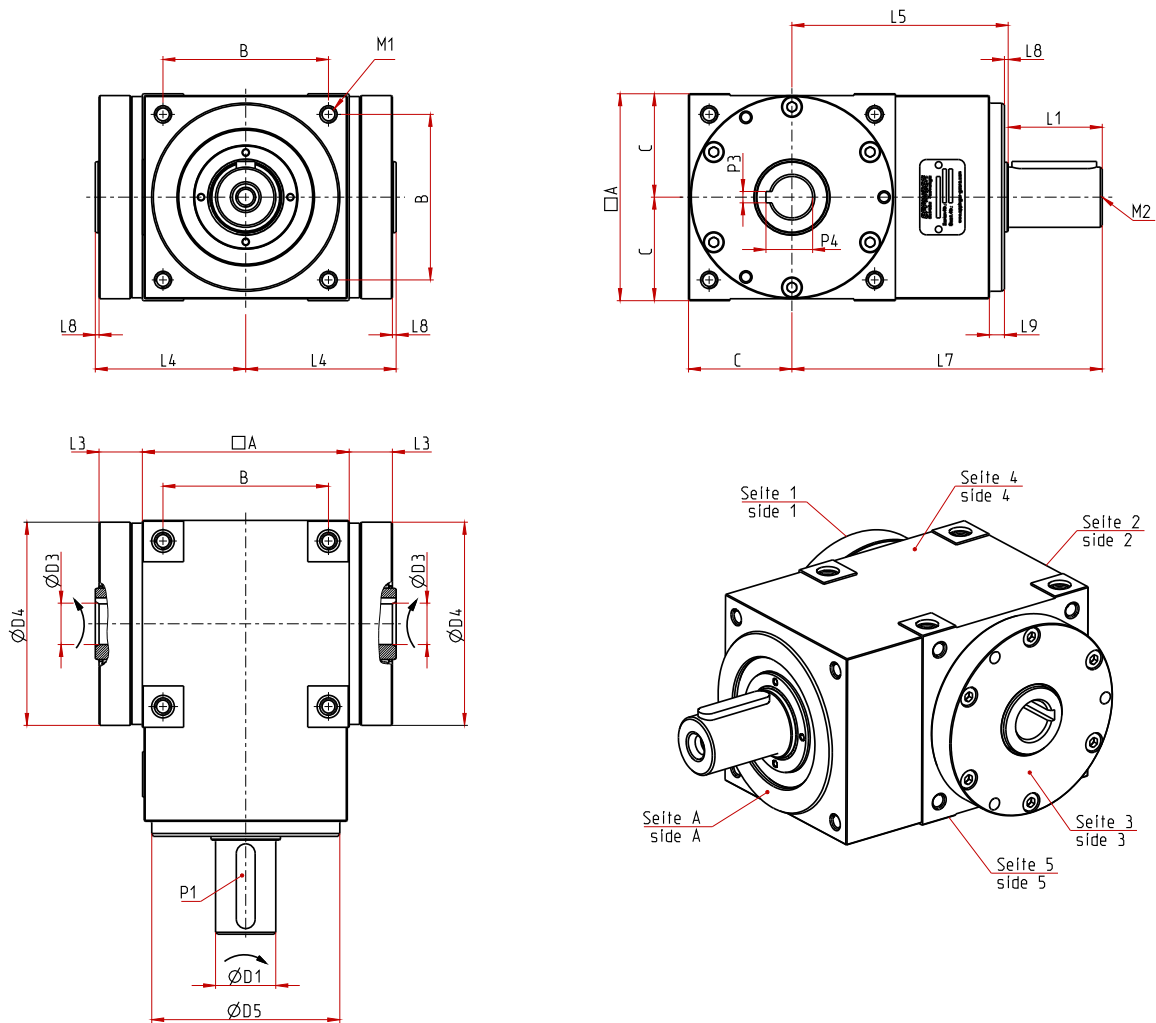

Hollow Shaft Design (dimensions in mm)

	BT050	BT075	BT090	BT110	BT140	BT170	BT210	BT240	BT280
□ A	50	75	90	110	140	170	210	240	280
B	38	60	72	88	110	134	170	190	220
C	25	37,5	45	55	70	85	105	120	140
Ø D1	12 k6	18 k6	20 k6	25 k6	32 k6	40 k6	50 k6	60 k6	70 k6
Ø D3	9 H7	14 H7	18 H7	22 H7	32 H7	40 H7	50 H7	60 H7	70 H7
Ø D4	49 h7	73 h7	88 h7	108 h7	135 h7	165 h7	205 h7	235 h7	275 h7
Ø D5	45 g6	67 g6	80 g6	100 g6	120 g6	128 g6	158 g6	178 g6	208 g6
L1	23	30	35	40	50	60	80	100	120
L3	8,5	14,5	15	15	18	15	20	25	25
L4	35,5	54	62	72	90	102	127	147	167
L5	60	90	100	115	130	155	190	215	250
L7	83	120	135	155	180	215	270	315	370
L8	2	2	2	2	2	2	2	2	2
L9	5	6	8	8	8	10	14	68	83
P1	4x4x18	6x6x25	6x6x28	8x7x32	10x8x45	12x8x50	14x9x70	18x11x90	20x12x100
P3	3 J59	5 J59	6 J59	6 J59	10 J59	12 J59	14 J59	18 J59	20 J59
P4	11,4	16,3	20,8	24,8	35,3	43,3	54,3	64,4	74,9
M1	M5x9	M5x10	M6x12	M8x16	M10x20	M12x24	M16x32	M16x32	M16x32
M2*	M4	M6	M6	M8	M10	M16	M16	M20	M20

* Thread in shaft end acc. to form DS, DIN 332

EPPINGER precision gear boxes at a glance



Our product range includes besides **bevel-, hypoid-, planetary- and cycloidal gear boxes** also **special customized gear boxes and high precision gear technology**. With our **gear motors and integrated combinations of our gear box series** we extended our portfolio. The **compact mono-bloc design** as well as our maximum **gear quality** makes our solutions **unique**.

Ordering code

	Type of gear box	Size	Type of shaft	Ratio
Example for ordering: BT090 S13 1.5:1	BT	050	S01 - Solid shaft side 1	i = 1 : 1
		075	S03 - Solid shaft side 3	i = 1.5 : 1
		090	S13 - Solid shaft sides 1+3	i = 2 : 1
		110		i = 3 : 1
		140	H13 - Hollow shaft sides 1+3	i = 4 : 1
		170		i = 5 : 1
		210		
		240		
280				

Upon request: motor flange, different shaft dimensions, customized solutions, fittings,....

Subject to change in design. We recommend technical clarification prior to ordering.



EPPINGER 
PRECISION GEAR SOLUTIONS